

A08H Technical Specification

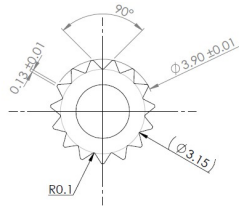

15T 4mm Output Shaft Spline

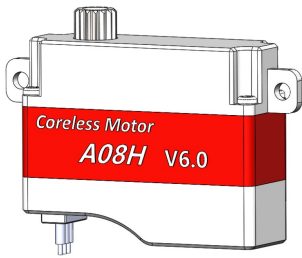
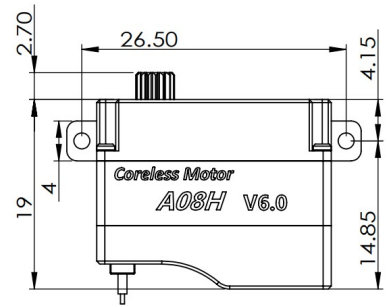
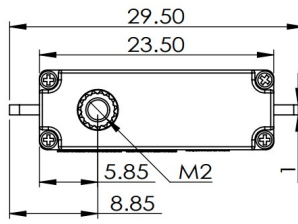

1. Operating Data

A08H	
Rated Voltage	DC7.4V
Voltage Range	DC3.8V-8.4V
Torque	14N.cm@3.8V
	22N.cm@6.0V
	28N.cm@7.4V
	32N.cm@8.4V
Speed	0.20sec/60°@3.8V
	0.13sec/60°@6.0V
	0.10sec/60°@7.4V
	0.09sec/60°@8.4V
Working Frequency	1520us/20KHz
Default Travel Angle	±60° = 120° Total
Temperature Range	-10°C+65°C
Case Material	Aluminum Alloy
Motor Type	Coreless DC Motor
Gear Set Material	Hardened Steel
Position Sensor	Potentiometer
Case Dimensions	23.5mm*8mm*19mm±0.2mm
Weight	7g±10%

2. Performance

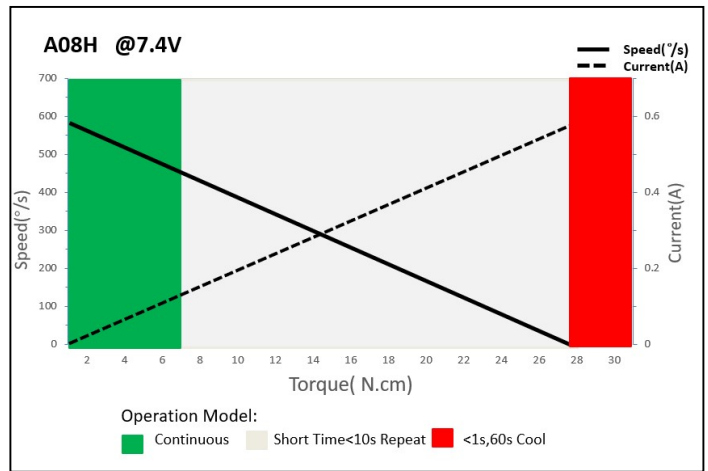

3. Command signal

PWM Command Interface

Signal Voltage	HIGH: min.3.3V, max.5.0V Low: min.0.0V, max.1.5V
Pulse Lengths	900us-2100us
Pulse Lengths for Position -60°/ 0°/+60°	1000us/1500us/2000us

4. Electrical Connection

 3 2 1	Pin Assignment			
	1	Orange	Signal	PWM Command
	2	Red	DC+	Supply Voltage
	3	Brown	DC-	Supply Ground