

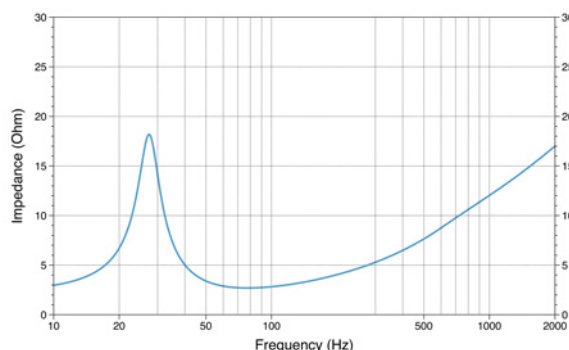

APS 10 D SUBWOOFER

- 1 Ultra-low profile (4.7 in. / 120 mm) for maximum installation flexibility.
- 2 Designed to deliver maximum performance in a sealed enclosure starting from 10 lt.
- 3 Special designed cone-dustcap-basket geometry which guarantees a long linear excursion capability (11 mm, one-way) while keeping the mounting depth to minimum.
- 4 Air vents on the basket underneath the spider, eliminating the need for the central pole vent allowing mounting close to rear wall of enclosure.
- 5 Massive motor assembly, optimized with FEM (Finite Element Modeling) for perfect control under high power, high excursion conditions.
- 6 Water-repellent treated paper 10 in. cone, featuring a profile developed with FEM simulation and optimized with the Klippel Scan Vibrometer.
- 7 Dual voice coil design specifically developed to be combined with either AP8.9 bit (2 CH + 2 CH bridged), AP5.9 bit (Sub CH) or AP4.9 bit/AP4 D (2 CH bridged) amplifiers.
- 8 Steel mesh grille and plastic gasket included.

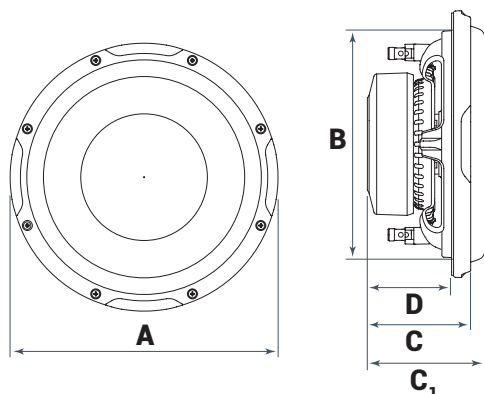

A	B	C	C ₁	D	
270	233	105	119	88	mm
10.63	9.17	4.13	4.69	3.46	in.

TECHNICAL SPECIFICATIONS

Component	SUBWOOFER	
Subwoofer size	mm (in.)	250 (10)
Subwoofer Voice coil Ø	mm (in.)	60 (2.36)
Power handling	W peak	800
	W continuous	400
Impedance	Ω	4+4
Centre to centre distance	mm (in.)	255 (10.04)
Midrange magnet size D-d-h	mm (in.)	140 (5.51) x 70 (2.76) x 30 (1.18)
Total driver displacement	l (cu.in.)	1,12 (0.02)
Hole diameter	mm (in.)	5 (0.2)
Weight of one speaker	kg (lb)	5,245 (11.56)
Magnet	High density flux ferrite	
Cone	Water repellent pressed paper	
*Xmech	mm (in.)	±18 (0.71)

ELECTRO-ACOUSTIC PARAMETERS

D	mm	220
X _{max}	mm	±11
R _e	Ω	2,2
F _s	Hz	27
L _e	mH	1,5
V _{as}	l	41
M _{ms}	g	170
C _{ms}	mm/N	0,2
BL	T·m	10,4
Q _{ts}		0,52
Q _{es}		0,58
Q _{ms}		4,7
Spl	dB	84