



INSTALLATION INSTRUCTIONS FRONT PLOW MOUNTING KIT

Part Number: 80681*

Application: Polaris RZR

*For use with WARN Plow Base 92100 (ATV)

Your safety, and the safety of others, is very important. To help you make informed decisions about safety, we have provided installation and operating instructions and other information on labels and in this guide. This information alerts you to potential hazards that could hurt you or others. It is not possible to warn you about all potential hazards associated with this product, you must use your own good judgment.

CARELESS INSTALLATION AND OPERATION CAN RESULT IN SERIOUS INJURY OR EQUIPMENT DAMAGE. READ AND UNDERSTAND ALL SAFETY PRECAUTIONS AND OPERATING INSTRUCTIONS BEFORE INSTALLING AND OPERATING THIS PRODUCT.

This guide identifies potential hazards and has important safety messages that help you and others avoid personal injury or death. **WARNING** and **CAUTION** are signal words that identify the level of hazard.

These signal words mean:

WARNING signals a hazard that *could* cause serious injury or death, if you do not follow recommendations. **CAUTION** signals a hazard that *may* cause minor to moderate injury, if you do not follow recommendations.

This guide uses **NOTICE** to call attention to important mechanical information, and **Note**: to emphasize general information worthy of special attention.

WARNING

INJURY HAZARD

Failure to observe these instructions could lead to severe injury or death.

- Always Read the Plow Operator's Manual, the Winch Operator's Manual and all warning labels before operating.
- Always use extreme caution when drilling on any vehicle. Make sure that all fuel lines, brake lines, electrical wires, and other objects are not punctured or damaged when/if drilling on the vehicle. Thoroughly inspect the area to be drilled (on both sides of material) prior to drilling, and relocate any objects that may be damaged. Failure to inspect the area to be drilled may result in vehicle damage, electrical shock, fire or personal injury.
- Always wear safety glasses when installing this kit. A drilling operation will cause flying metal chips. Flying chips can cause eye injury.
- Always use extreme caution when cutting and trimming during fitting.
- Always remove jewelry and wear eye protection.
- Never lean over battery while making connections.
- Never route electrical cables:
 - o Across any sharp edges.
 - o Through or near moving parts.
 - o Near parts that become hot.
- Always insulate and protect all exposed wiring and electrical terminals.
- Always install terminal boots as directed in installation instructions.
- Always use appropriate and adequate care in lifting components into place.
- Always insure components will remain secure during installation and operation.
- Always tighten all nuts and bolts securely, per the installation instructions.
- Always operate the vehicle at a walking speed with the blade installed. Never exceed 5 mph (8 km/h), even with blade up.
- Always plow cautiously, impact with hidden or stationary object may cause the vehicle to stop suddenly or go out of control.
- Never operate the vehicle on slopes greater than 10 degrees with the plow installed.
- Never stand or ride on the plow.
- Always stay clear of moving parts and joints. Always keep others away when operating or adjusting plow.
- Always perform regular inspections and maintenance on the plow mechanism, fasteners, cable and related hardware.
- Always replace all worn or damaged parts before operating.
- Never operate this WARN product with damaged or missing parts.
- Always drive slowly over bumpy and rough terrain. Driving at speeds that cause the plow to bounce while in the up position can cause the winch to back-drive, causing the plow to work its way down. This may result in the plow impacting a stationary object and cause damage to the vehicle and operator injury or death.
- Always drive at speeds such that the plow does not bounce and be aware of the plow position while driving at all times.
- Always be aware that the purpose of the j-bolt is to break the connection between the plow and the winch, to prevent serious damage to the ATV if the plow is raised too high. The plow blade will drop suddenly if the j-bolt breaks, so always be sure there are no bystanders when you raise and lower the plow.
- Never raise the top of the plow above the headlights of the ATV, as it may damage the vehicle and plow.
- Always replace a deformed or broken j-bolt with the spare j-bolt included in the kit.

⚠ Caution
Moving Parts Entanglement Hazard
Failure to observe these instructions could lead to minor or moderate injury.
<input type="checkbox"/> Always take time to fully read and understand the installation and Operations Guide included with this product. <input type="checkbox"/> Never operate this product if you are under 16 years of age. <input type="checkbox"/> Never operate this product when under the influence of drugs, alcohol or medications.
Read installation and operating instructions thoroughly.

Notice
Equipment Damage
<input type="checkbox"/> Always refer to the Installation and Specification Guide, supplied in the winch kit, for all wiring schematics and specific details on how to wire this WARN product to your vehicle. <input type="checkbox"/> Never overtighten the j-bolt to the bracket. Doing so will pinch the winch cable against the bracket, damaging the cable. <input type="checkbox"/> Always put the end of the actuator cable through the slot in the Termination Bracket. Terminating the cable through any other hole in the bracket will cause the bracket to not function properly and will drastically reduce the life of the actuator cable.
Read installation and operating instructions thoroughly.

II. TABLE OF CONTENTS

Tools Required	page 2
Torque Specifications	page 2
Parts List	page 3
Installation	page 4-6
Maintenance/Care	page 7
Tips/Troubleshooting	page 7

III. TOOLS REQUIRED

- RATCHET
- 1/2, 12mm, 13mm, SOCKET
- 1/2, 12mm, 13mm, WRENCH

IV. TORQUE SPECIFICATIONS

	Grade 8.8 Only
M6	10.5 N-m (8 lb. ft.)
M8	26 N-m (17 lb. ft.)
M10	51 N-m (30 lb. ft.)
M12	89 N-m (50 lb. ft.)
M14	141 N-m (75 lb. ft.)

V. PARTS LIST

Reference	Part Number	Qty	Description
A1	82373	1	BRKT MAIN SUPPORT PM POL RZR
A2	82623	1	WELDMNT BRKT LF SUPPORT FPM POL RZR
A3	82602	1	WELDMNT BRKT RH SUPPORT FPM POL RZR
A4	82908	1	BRKT SUPPORT FPM POL RZR
A5	79340	1	WLDMNT OFFSET BOLT ON FPM RH PUSH TUBE (NOT SHOWN)
A6	79341	1	WLDMNT OFFSET BOLT ON FPM LH PUSH TUBE (NOT SHOWN)
B1	61262	4	5/16-18 U-BOLT
B2	1324	8	5/16" ID, FLAT WASHER
B3	1320	4	1/4 FLAT WASHER
B4	78648	12	M8-1.25 X 20MM HEX FLANGE BOLT
B5	66129	16	M8-1.25, FLANGE LOCKING HEX NUT
B6	21445	2	1/4-20 U-BOLT
B7	65970	4	M8-1.25 X 25mm HEX FLANGE BOLT
B8	2002	8	5/16-18 LOCKING HEX NUT
B9	6725	4	1/4-20 LOCKING HEX NUT
C1	79712	2	3/8" DIA. L- CLIP RETAINING PIN

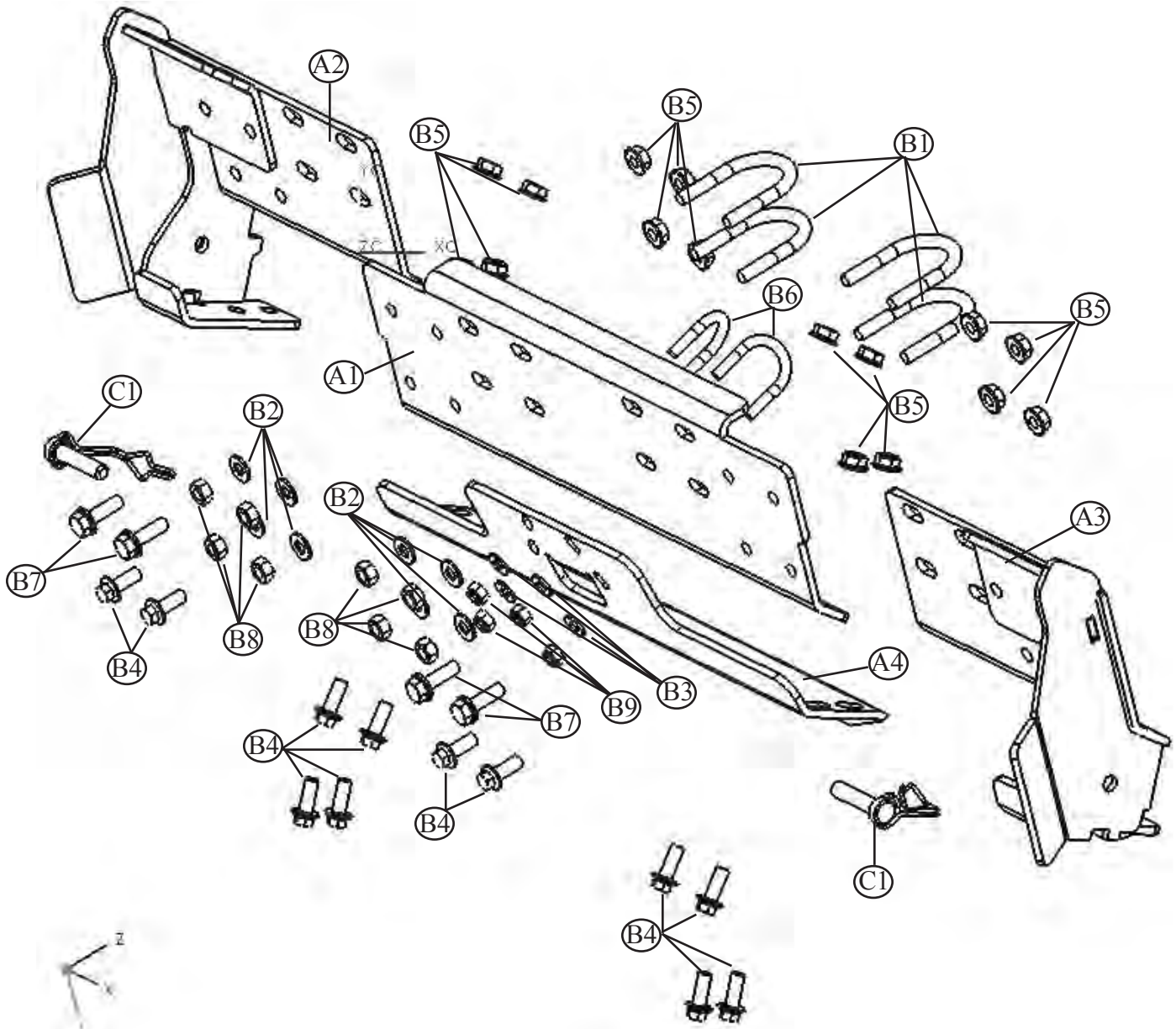

VI. INSTALLATION

1. Remove the front cover. Remove the 4 torx fasteners attaching the front bumper cover. The bumper cover needs to be loose to be able to lift out of the way and allow more room to work. See figure one.

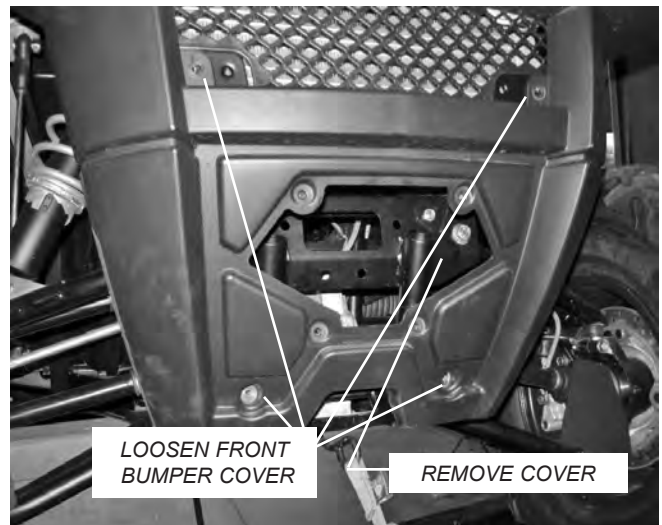

Figure 1

2. Next, attach the front lower support bracket (A4).



Figure 2

3. Two 1/4-20 u-bolts (B6) will go around the front tow bar. The bent out section on the lower support bracket (A4) will lock over the lower edge of the tow bar opening. See figures three and four.

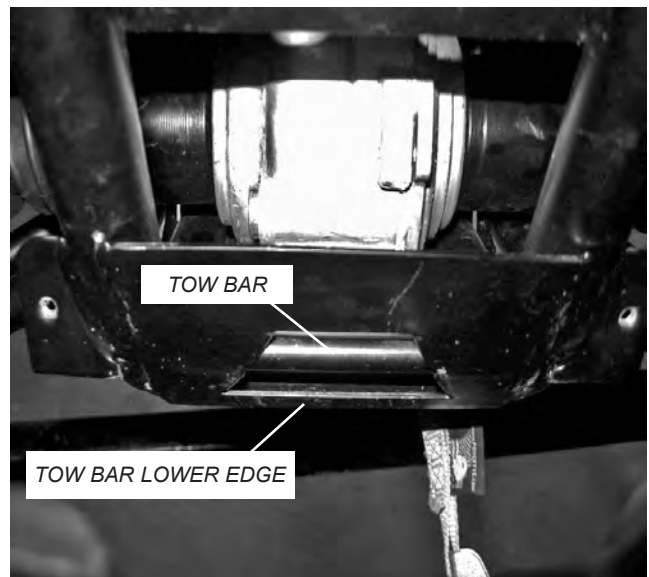

Figure 3

INSTALLATION CONT.

5. Place the two 1/4-20 u-bolts (B6) into position. Use four flat washers (B3) and four locking 1/4-20 hex nuts (B9); see figure four. Do not tighten at this time, all fasteners will need to remain loose until all fasteners are in place.



Figure 4

6. Slip the main support bracket (A1) behind the two main frame tubes; see figure 5.

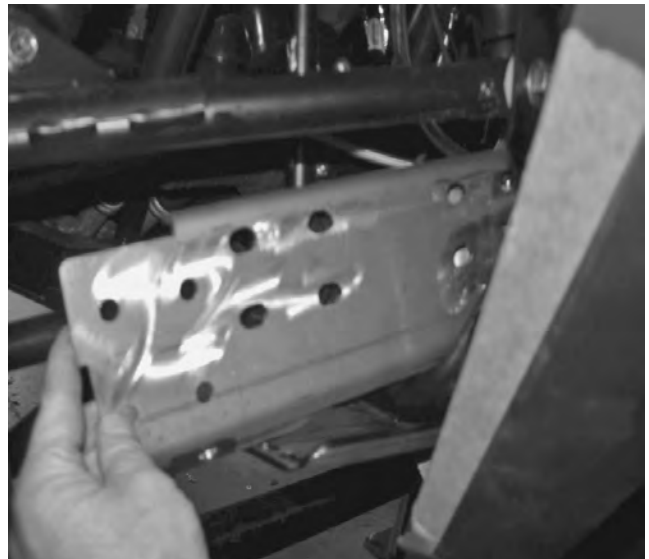

Figure 5

7. Slip the left and right plow end supports (A2, A3) into position over the end of the main support bracket (A1); see figure 6.

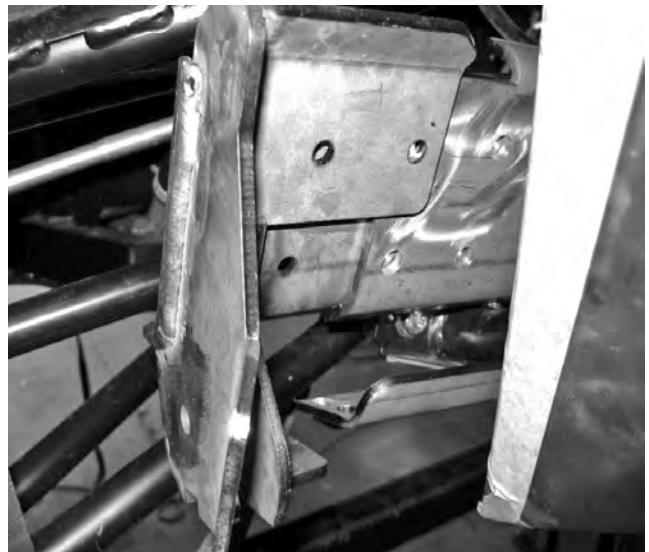

Figure 6

INSTALLATION CONT.

8. Once the end supports (A2, A3) are into position the lower tab on the end supports must be attached to the lower support bracket (A4). Use two M8-1.25 x 20mm flanged hex bolts (B4) and two M8-1.25 flanged locking hex nuts (B5). Do not tighten these fasteners at this time.



Figure 7

9. Once the lower tabs are secured attach the end supports (A2, A3) to the support plate (A1) using four M8-1.25 x 20mm flanged hex bolts (B4) and four M8-1.25 flanged locking hex nuts (B5) on the four lower attachment points. Use the M8-1.25 x 25mm flanged hex bolts (B7) and M8-1.25 flanged locking hex nuts (B5) on the top two attachment points; see figure 8. Do not tighten these fasteners at this time.

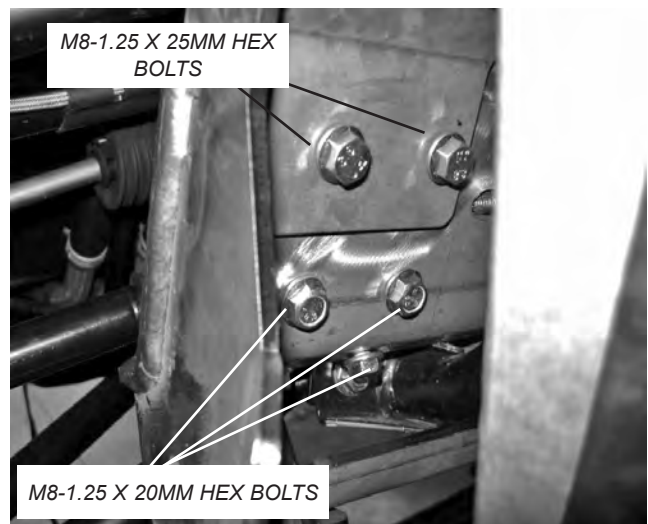

Figure 8

10. Place the four 5/16-18 u-bolts (B1) around the frame tubes and into the end support bracket (A2, A3) and the main support bracket (A1) secure using eight 5/16 flat washers (B2) and eight 5/16-18 locking hex nuts (B8). The main support plate (A1) will need to be lifted as high as possible to allow for the clearance of the lower u-bolt; see figure 9.

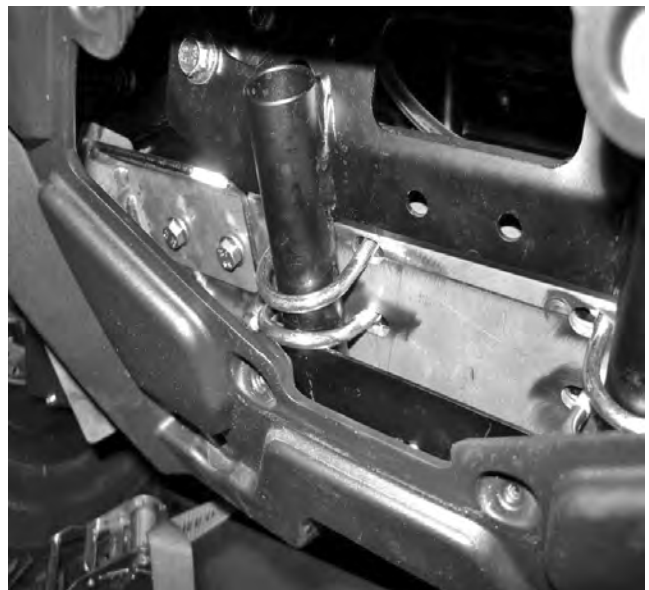

Figure 9

INSTALLATION CONT.

11. Go back through the installation and tighten all the fasteners at this point.
12. The lower portion of the plastic bumper cover will need to be trimmed to allow it to go back into position. The indicated area should be trimmed this should allow for the plastic bumper cover to move back into the correct position; see figure ten.

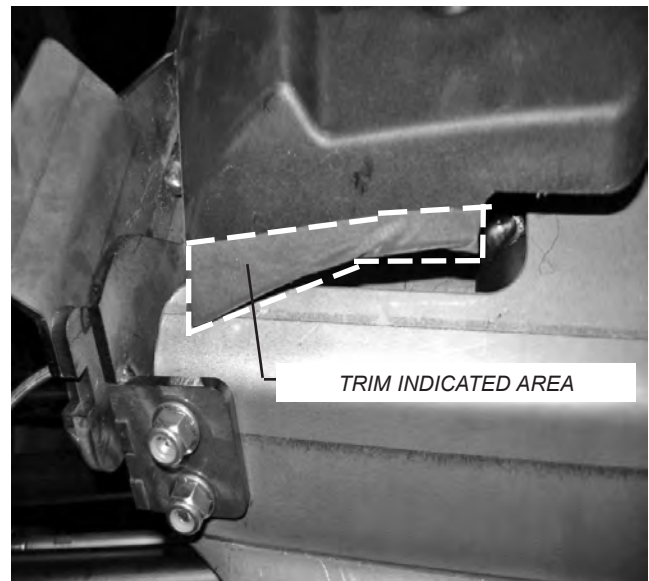

Figure 10

13. The side of the plastic bumper cover may need to be trimmed as well. If it comes into contact with the upper portion of the end supports only a small amount may need to be trimmed; see figure eleven. It may be possible to squeeze the cover in and slip it by the end support. Once the cover can fit back into position attach using the hardware removed in step one.



Figure 11

14. The plow extension tabs will attach to the plow tube assembly, the extension tabs should go to the outside of the tabs on the plow tube with the jogs and the pucks facing out, this is the widest possible position for the plow extension tabs. The fasteners for attaching the extension tabs will be found in the plow tube kit, 6 M10 hex bolts and M10 hex nuts.

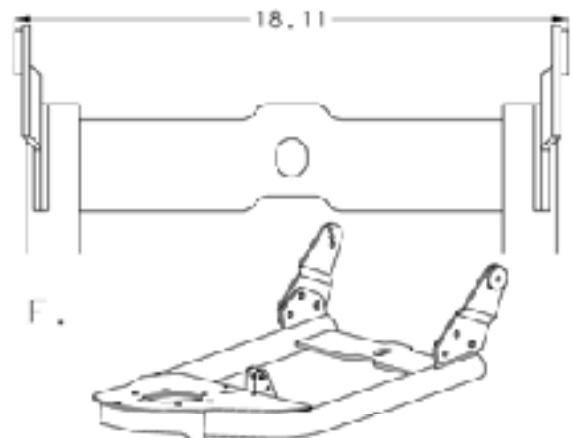

Figure 12

VI. MAINTENANCE/CARE

- Inspect all metal parts on the plow, plow mount, and related hardware. Replace all parts that appears rusted or deformed prior to use.
- Inspect all nuts and bolts on the plow, plow mount, and related hardware prior to each use. Tighten all nuts and bolts that appear to be loose. Stripped, fractured, or bent bolts or nuts need to be replaced immediately.
- Check all cables prior to use. Replace cables that are worn or frayed.
- Check all moving and rotating parts. Remove debris that may inhibit the part from moving freely.

VII. TROUBLE SHOOTING

Trouble	Inspection	Diagnosis	Action
Difficulty getting bolts to line up with holes in chassis.	A. Check that the side slots in skidpan align with the hole and nut in the chassis.	1. Make sure the skidpan slots aligns with the hole when the mount is not compressed against it.	1. Adjust and move the skidpan while compressing the plow mount against it until the skidpan slots align with the hole.
		2. Make sure the skidpan slots align with the hole when the U-bolts are put through the skidpan.	2. Increase the diameter or slot the holes drilled through the skidpan until the skidpan slots align with the holes.
Difficulty getting plow pins through the plow and plow mount.	A. Check the alignment of the plow mount holes in relation to the plow holes.	1. Make sure the plow and vehicle are both on a flat non-sloping surface.	1. Move the plow and vehicle to a flat non-sloping surface.
		2. Make sure the plow holes align perfectly with the plow mount holes.	2. Place a smaller diameter rod (such as a drill bit) through the holes and align the two. Once the two are aligned, hold the plow in place and put the plow pin through the two holes.
The electric actuator cable will not rotate within the termination bracket.	A. Check the termination of the actuator cable.	1. Make sure the cable is in the slot of the termination bracket, the cylindrical pin is attached to the cable, and the termination bracket is attached such that it leans toward the plow blade.	1. Mount the bracket to the plow crossmember on the plow blade side angling toward the blade. Slide the end of the actuator cable through the termination bracket slot. Slide the cylindrical pin over the end of the cable and terminate with a 1/4" nut (D). The completed assembly should look like Figure 12.