



INSTALLATION INSTRUCTIONS ATV Front Plow Mount Kit

Part Number: 80031

Applications: 2007+

2007+

2009+

Honda Rancher 420

Honda Rancher ES 420

Honda Rancher AT 420

****Not compatible with 2.5ci or A2000 winches***

Your safety, and the safety of others, is very important. To help you make informed decisions about safety, we have provided installation and operating instructions and other information on labels and in this guide. This information alerts you to potential hazards that could hurt you or others. It is not possible to warn you about all potential hazards associated with this product, you must use your own good judgment.

CARELESS INSTALLATION AND OPERATION CAN RESULT IN SERIOUS INJURY OR EQUIPMENT DAMAGE.
READ AND UNDERSTAND ALL SAFETY PRECAUTIONS AND OPERATING INSTRUCTIONS BEFORE INSTALLING AND OPERATING THIS PRODUCT.

This guide identifies potential hazards and has important safety messages that help you and others avoid personal injury or death. **WARNING** and **CAUTION** are signal words that identify the level of hazard. These signal words mean:

▲ WARNING signals a hazard that *could* cause serious injury or death, if you do not follow recommendations.

▲ CAUTION signals a hazard that *may* cause minor to moderate injury, if you do not follow recommendations.

This guide uses **NOTICE** to call attention to important mechanical information, and **Note**: to emphasize general information worthy of special attention.

▲ WARNING

INJURY HAZARD

Failure to observe these instructions could lead to severe injury or death.

- Always Read the Plow Operator's Manual, the Winch Operator's Manual and all warning labels before operating.
- Always use extreme caution when drilling on any vehicle. Make sure that all fuel lines, brake lines, electrical wires, and other objects are not punctured or damaged when/if drilling on the vehicle. Thoroughly inspect the area to be drilled (on both sides of material) prior to drilling, and relocate any objects that may be damaged. Failure to inspect the area to be drilled may result in vehicle damage, electrical shock, fire or personal injury.
- Always wear safety glasses when installing this kit. A drilling operation will cause flying metal chips. Flying chips can cause eye injury.
- Always use extreme caution when cutting and trimming during fitting.
- Always remove jewelry and wear eye protection.
- Never lean over battery while making connections.
- Never route electrical cables:
 - Across any sharp edges.
 - Through or near moving parts.
 - Near parts that become hot.
- Always insulate and protect all exposed wiring and electrical terminals.
- Always install terminal boots as directed in installation instructions.
- Always use appropriate and adequate care in lifting components into place.
- Always insure components will remain secure during installation and operation.
- Always tighten all nuts and bolts securely, per the installation instructions.
- Always operate the vehicle at a walking speed with the blade installed. Never exceed 5 mph (8 km/h), even with blade up.
- Always plow cautiously, impact with hidden or stationary object may cause the vehicle to stop suddenly or go out of control.
- Never operate the vehicle on slopes greater than 10 degrees with the plow installed.
- Never stand or ride on the plow.
- Always stay clear of moving parts and joints. Always keep others away when operating or adjusting plow.
- Always perform regular inspections and maintenance on the plow mechanism, fasteners, cable and related hardware.
- Always replace all worn or damaged parts before operating.
- Never operate this WARN product with damaged or missing parts.
- Always drive slowly over bumpy and rough terrain. Driving at speeds that cause the plow to bounce while in the up position can cause the winch to back-drive, causing the plow to work its way down. This may result in the plow impacting a stationary object and cause damage to the vehicle and operator injury or death.
- Always drive at speeds such that the plow does not bounce and be aware of the plow position while driving at all times.
- Always be aware that the purpose of the j-bolt is to break the connection between the plow and the winch, to prevent serious damage to the ATV if the plow is raised too high. The plow blade will drop suddenly if the j-bolt breaks, so always be sure there are no bystanders when you raise and lower the plow.
- Never raise the top of the plow above the headlights of the ATV, as it may damage the vehicle and plow.
- Always replace a deformed or broken j-bolt with the spare j-bolt included in the kit.

⚠ Caution
Moving Parts Entanglement Hazard
Failure to observe these instructions could lead to minor or moderate injury.
<input type="checkbox"/> Always take time to fully read and understand the installation and Operations Guide included with this product. <input type="checkbox"/> Never operate this product if you are under 16 years of age. <input type="checkbox"/> Never operate this product when under the influence of drugs, alcohol or medications.
Read installation and operating instructions thoroughly.

Notice
Equipment Damage
<input type="checkbox"/> Always refer to the Installation and Specification Guide, supplied in the winch kit, for all wiring schematics and specific details on how to wire this WARN product to your vehicle. <input type="checkbox"/> Never overtighten the j-bolt to the bracket. Doing so will pinch the winch cable against the bracket, damaging the cable. <input type="checkbox"/> Always put the end of the actuator cable through the slot in the Termination Bracket. Terminating the cable through any other hole in the bracket will cause the bracket to not function properly and will drastically reduce the life of the actuator cable. <input type="checkbox"/> This kit design is compatible with RT/XT WARN winches. Other winches may not fit. Contact customer service with questions on application.
Read installation and operating instructions thoroughly.

Before You Begin

This kit is compatible with WARN's RT/XT line of ATV winches. Other winches may not fit.

Winch is sold separately. Please read WARN's Winching Technique guide provided with the winch prior to use of this product.

Table of Contents

I.	Tools Required.....	2
II.	Torque Specifications.....	2
III.	Parts List.....	3
IV.	Rancher Installation.....	4-6
V.	Maintenance/Care	7

I. Tools Required

- Ratchet
- Sockets: 10mm and 13mm
- Wrenches: 13mm

II. Torque Specifications

1/4, 6mm	8 lb. ft. (10.8 N-m)
5/16, 8mm	17 lb. ft. (22.5 N-m)
3/8, 10mm	30 lb. ft. (40.7 N-m)
7/16, 11mm	50 lb. ft. (67.8 N-m)
1/2, 12mm	75 lb. ft. (101.7 N-m)

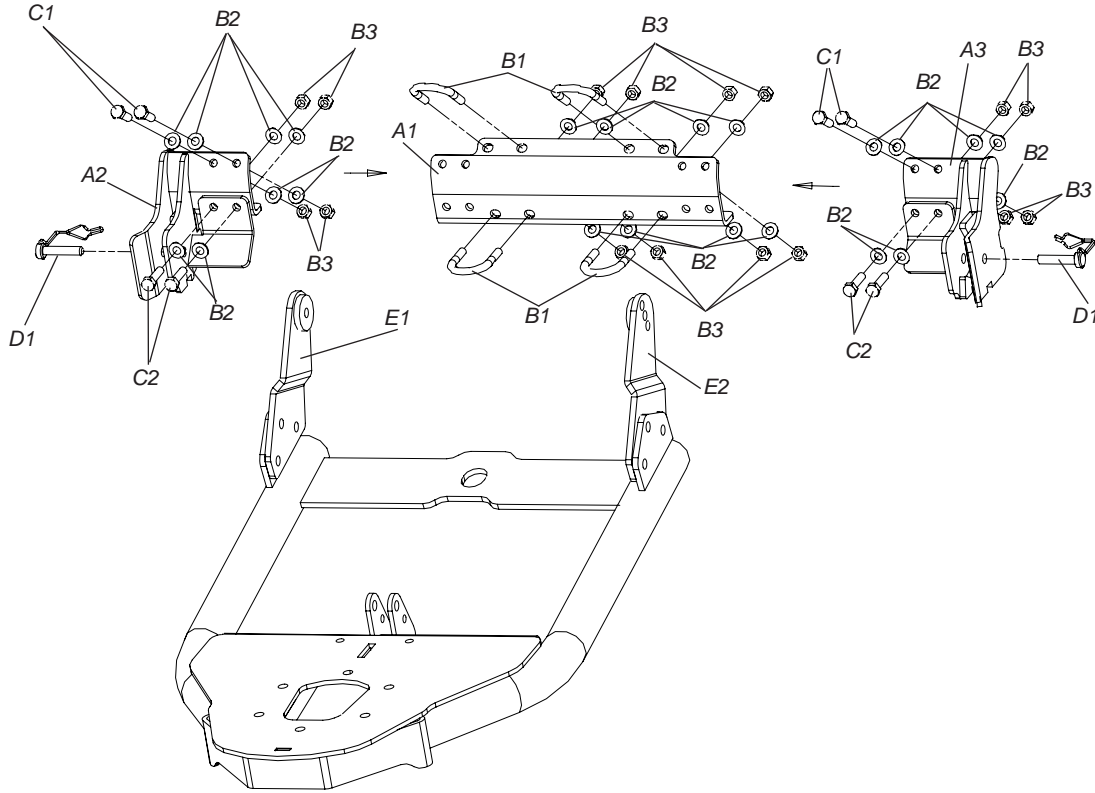

III. Parts List

<u>Ref</u>	<u>Part #</u>	<u>Description</u>	<u>Qty</u>
A1	81531	Base Mounting Bracket	1
A2	81851	RH Extension Weldment	1
A3	80030	LH Extension Weldment	1
B1	79413	U-bolt,M8-1.25x31x41	4
B2	1324	5/16" Flat Washer	24
B3	22491	M8 x 1.25 Lock Nut	16
C1	22508	M8x1.25x25mm Capscrew	4
C2	13454	M8x1.25x30mm Capscrew	4
D1	79712	3/8" Safety Retaining Clip	2
E1	79340	RH Bolt On Offset Weldment	1
E2	79341	LH Bolt On Offset Weldment	1

IV. Rancher Installation

1. Front plow mount kit will be mounted behind winch. Remove A-arm guards, shown in Figure 1, using a 10mm socket. These will be reinstated and trimmed later.

This mount will work either with or without the winch mount installed.



Figure 1

2. Slide base mounting bracket through vehicle frame in orientation as shown in Figure 2. Rotate as required to provide adequate clearance.

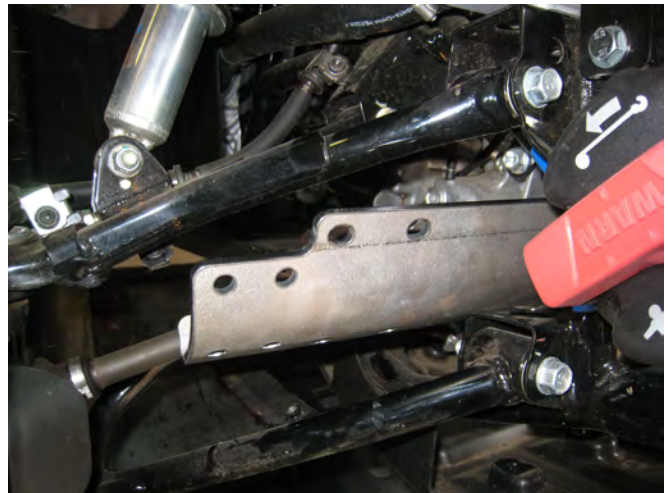

Figure 2

3. Slide u-bolts around vehicle tube frame and through mounting bracket, as shown in Figure 3. Secure top u-bolts first for better access using 5/16" flat washers and locknuts. Use a 13mm socket or wrench to tighten. Uniformly torque to 17lb.ft. (22.5 N-m). Bottom of mounting bracket should rest close to vehicle frame.



Figure 3

IV. Installation *continued*

4. Position right hand extension weldment in orientation, as shown in Figure 4, and slide onto the base mounting bracket.

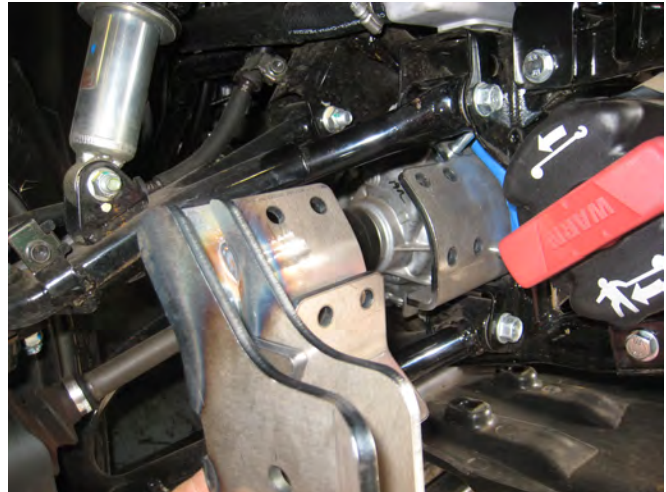

Figure 4

5. Secure extension weldment to bracket using M8x1.25x25mm capscrews, washers and locknuts on top mounting holes and M8x1.25x30mm capscrews, washers and locknuts on bottom mounting holes, as shown in Figure 5. For vehicles with a winch installed, the mounting hardware will need to be loosened to allow access to lower, inner capscrew (refer to step 6).



Figure 5

6. For vehicles with winch installed, remove the lower winch mount capscrews and loosen upper winch mount capscrews on both sides of vehicle to allow adequate clearance to install lower, inner capscrew on plow mount assembly (see Figure 6). Once plow mount hardware is installed and tightened, with a 13mm wrench or socket, torque to 17lb.ft (22.5 N-m). Reinstall and torque winch mounting hardware when complete per torque specifications on page 3.
7. Repeat procedure in steps 4-6 for the left hand extension weldment, shown in Figure 7. There will be adequate clearance to install capscrews on this side of the vehicle with winch installed.

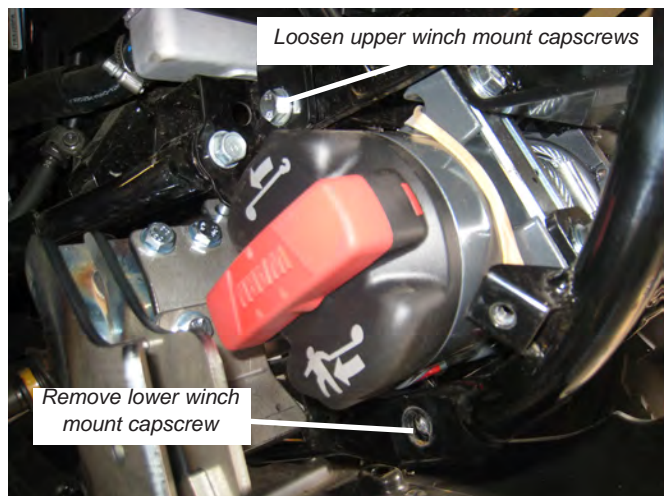

Figure 6

IV. Installation *continued*

8. Trim the front a-guards as required and reinstall on vehicle. Figure 8 shows a completed installation with front plow mount bolted in place.

9. Bolt on right hand and left hand offset tab weldments to push tube base in orientation shown in Figure on page 3. Hardware is supplied with the plow kit. Torque hardware to specification once proper fit has been verified with vehicle plow mount.



Figure 7

The front plow mount installation is now complete. Proceed to section V entitled "Maintenance/Care".



Figure 8

V. Maintenance / Care

- Inspect all metal parts on the plow, plow mount, and related hardware. Replace all parts that appears rusted or deformed prior to use.
- Inspect all nuts and bolts on the plow, plow mount, and related hardware prior to each use. Tighten all nuts and bolts that appear to be loose. Stripped, fractured, or bent bolts or nuts need to be replaced immediately.
- Check all cables prior to use. Replace cables that are worn or frayed.
- Check all moving and rotating parts. Remove debris that may inhibit the part from moving freely.

WARNING

READ THE VEHICLE'S OPERATOR MANUAL, WINCH OPERATOR MANUAL, AND ALL WARNING LABELS PRIOR TO OPERATION OF ATV AND WINCH.

WARNING

FAILURE TO SECURELY TIGHTEN ALL BOLTS ON THE PLOW MOUNT, WINCH PLATE, WINCH, AND FAIRLEAD CAN RESULT IN PRODUCT FAILURE WHICH MAY RESULT IN VEHICLE DAMAGE AND OPERATOR INJURY OR DEATH. DOUBLE CHECK THAT ALL BOLTS ARE SECURELY TIGHTENED PRIOR TO USE.

WARNING

PERFORM REGULAR INSPECTIONS ON THE PLOW, PLOW MOUNT, AND RELATED HARDWARE. NEVER OPERATE THE PLOW WITH DAMAGED OR MISSING PARTS. FAILURE TO FOLLOW THIS WARNING MAY CAUSE VEHICLE DAMAGE AND OPERATOR INJURY OR DEATH.