

RD149

Nissan M226,32 SPL,10 bolt RG

PARTS LIST

ITEM #	QTY	DESCRIPTION	PART #	NOTES
01	1	FLANGE CAP KIT	027321SP	
02	1	BONDED SEAL	160702SP	
03	1	CLUTCH GEAR & WAVESPRING KIT	050906SP	5
*	1	CLUTCH GEAR & RETURN SPRINGS KIT	050806SP	5
04	1	SPIDER BLOCK	070201SP	
05	1	LONG CROSS SHAFT	060204SP	
06	4	PINION GEAR	SEE NOTE	2
07	4	PINION THRUST WASHER	SEE NOTE	3
08	1	SIDE GEAR	SEE NOTE	2
09	2	SIDE GEAR THRUST WASHER	SEE NOTE	3
10	1	DIFFERENTIAL CASE (SUITS WAVESPRING ONLY)	013046SP	4
*	1	DIFFERENTIAL CASE (SUITS RETURN SPRINGS ONLY)	013021SP	4
11	1	COUNTERSUNK SCREW (PK OF 2)	200213SP	
12	1	RETAINING PIN SET (PK OF 4)	120601SP	
13	-	TAPERED ROLLER BEARING	NOT SUPPLIED	
14	1	SEAL HOUSING KIT	081809SP	
15	1	SEAL HOUSING O-RINGS (PK OF 2)	160207SP	1
16	1	WAVESPRING	150706SP	5
*	1	RETURN SPRINGS KIT	150113SP	5
17	1	SPLINED SIDE GEAR	SEE NOTE	2
18	2	SHORT CROSS SHAFT	060403SP	
*	1	BULKHEAD FITTING KIT (BANJO TYPE)	170114	6
*	1	AIR LINE (6mm DIA X 6m LONG)	170314	6
*	1	SOLENOID VALVE (12V)	180103	
*	1	SWITCH	180209SP	
*	1	SWITCH COVER (REAR)	180211SP	
*	1	CABLE TIE (PK OF 25)	180305	
*	1	OPERATING & SERVICE MANUAL	210200	
*	1	INSTALLATION GUIDE	2102149	

* *Not illustrated in exploded view*

NOTES

- 1 For replacement O-rings use only BS136 Viton 75.
- 2 Available only as complete 6 gear set # 728H171.
- 3 Available only as complete thrust washer kit #730H01.
- 4 Identify the spring type in your diff and order the correct diff case to replace.
- 5 Replace the spring and/or the corresponding clutch gear with the same type.
(If spring type is changed, a matching diff case must also be used. See item 10.)
- 6 All diffs produced before serial #17070001 came with 5mm air connection system. For information contact ARB.
- For models with 12 bolt Ring Gear refer to RD159 ([Section 2.159](#)).

RD149

Nissan M226,32 SPL,10 bolt RG

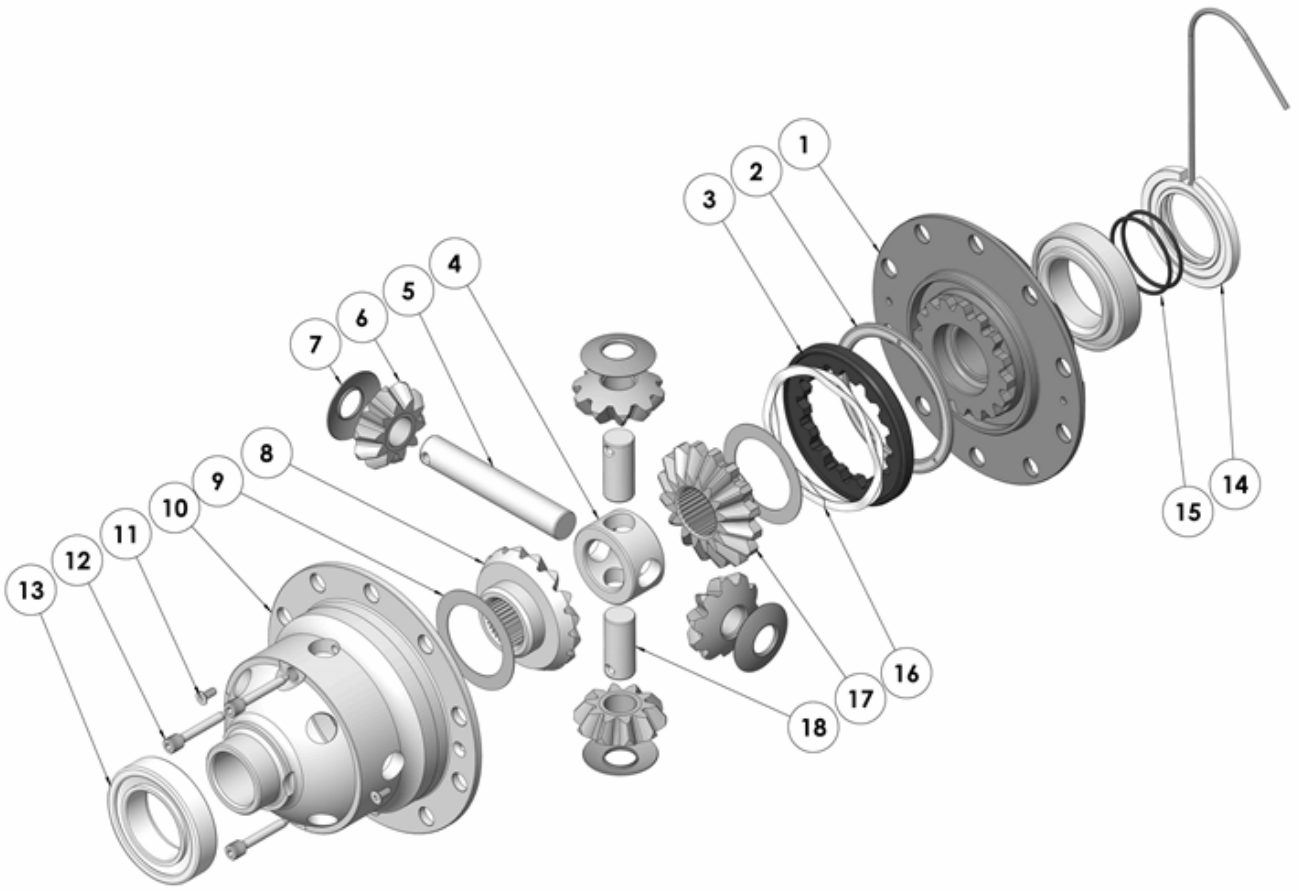
EXPLODED DIAGRAM**SPECIFICATIONS**

Axle Spline	32 tooth, Ø35.8mm [1.41"]
Ratio Supported	All
Ring Gear ID	141.3mm [5.56"]
Ring Gear OD	226mm [8.9"]
Ring Gear Bolts	10 bolts on Ø168.3mm [6.63"]
Ring Gear Torque	198Nm [146 ft-lb]
Backlash	0.08-0.13mm [0.003-0.005"]
Bearing Cap Torque	108Nm [80 ft-lb]

ARB Corporation Ltd • 42-44 Garden St Kilsyth VIC 3137 Australia
ARB 4X4 Accessories USA • 720 SW 34th St Renton WA 98057 USA
Australia & International Customer Service • +61 3 9761 6622
North America Customer Service • Toll Free 866 293 9078
www.arb.com.au (AUS & Int) www.arbusa.com (N. America)